



Data Sheet

ref: KLF1584.3

**10"HP (254mm) HIGH PERFORMANCE FAN**

**Part No: 10.HP.B.12V**

- 1,668m<sup>3</sup>/h volume of air @ 3.75mm wg static pressure.
- Jet turbine stator vane feature.
- High performance dedicated blower fan with advanced curved blades, for suction fan application use 10.HP.S.12V.
- Continuously rated for durability and long life.
- Manufactured to British Standards ISO9001 TS16949.
- Airflow performance verified by **MIRA**
- Integral multi point mounting housing/ducting.
- Low Noise ■ Colour: black. ■ Weight: 1.0kg.

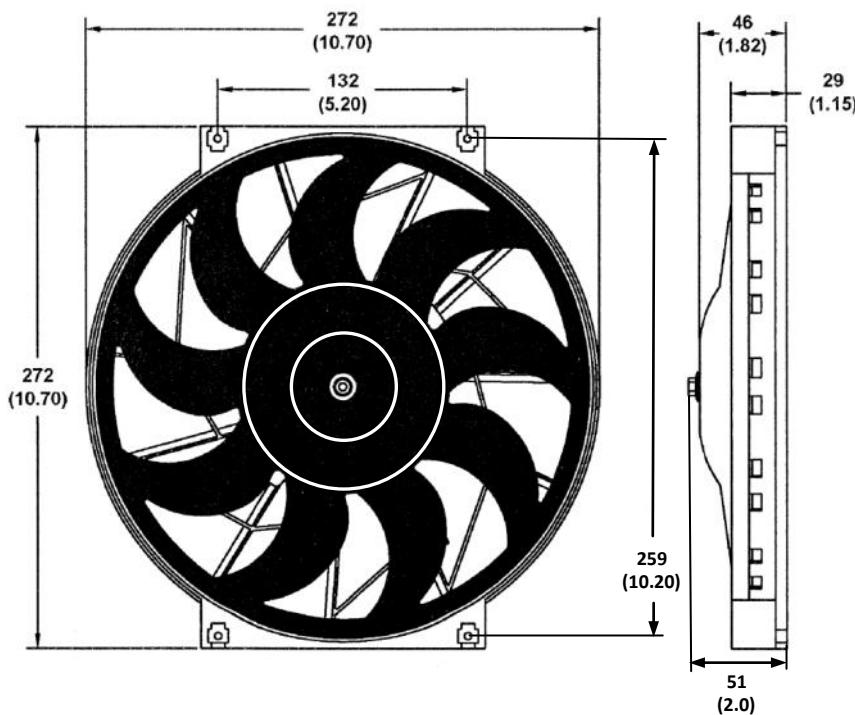

Mounting hole sizes 4mm.

Ducting width can be reduced by 3mm each side.

Negative or positive earth compatible.

Wires supplied with self sealing weatherproof male and female connectors/insulation shrouds.

Amps @ 13.5V	Airflow @ m <sup>3</sup> /h	Static pressure (mm) wg	Dia. (mm) overall	Tip (mm) thickness	Overall (mm) thickness	Voltages available
9	1668	3.75	272	29	51	12V

Note: Performance @ 3.75 mm w.g. represents a typical standard radiator air resistance. Advanced curved blades ensure a high level of exit airflow even on thicker radiators for maximum heat removal. Amps is an indicator of work done - low amps mean low airflow, particularly against thick or dense radiators.

Special specifications can be supplied—please contact our technicians with details of your requirements.

When ordering state voltage and airflow direction B for blowing or S for suction.

Fans manufactured to automotive industry original equipment British standards.



Airflow performance verified independently by the motor industry research association.



A British company established for over 57 years. Worldwide pioneers of thermo electric fans, made to be the best today.



**OPTIONAL EQUIPMENT**

- 1 OEM original equipment fan only units or retrofit fan/thermostat/mtg packages.
- 2 Regular fan range sizes 6" 7" 8" 9" 10" 11" 12" 13" 14" 16".
- 3 High performance fan range sizes 10" 12" 14" 17" with 2<sup>nd</sup> jet boost speed. (10" single speed).
- 4 Sealed and waterproof 12V motor options are available on 7" 8" 9" 11" regular performance blower/suction fans and 12" 14" 17" suction fans from the High Performance range.

**TEMPERATURE CONTROL OPTIONS**

- 6 \* Electronic adjustable non-invasive 'external' sensor suitable for all negative earth vehicles. Single speed 'regular fan' Ref: KLM2150 with pre-wired harness.
- 7 Electro mechanical adjustable 'in water' sensor fits without drilling radiator or cutting hose. Suits all negative/positive earth cars Ref: KLM1416.

**MOUNTING OPTIONS**

- 8 \* 'Fast fit' 4 pt nylon clamping system sealing fan to radiator – no drilling Ref: KLM2115.
- 9 4 pt set of mounting lugs to provide additional mounting points i.e. for frame mounting. Side Ref: KLM2274. End Ref: KLM2276.
- 10 Adjustable fan to body, fully adaptable mounting set Ref: KLM2116. Add B or S suffix for blower or suction fan fittings.

**MANUAL CONTROL/INDICATOR**

Light with wiring harness. Ref: KLM0570.

**SAFETY GUARD** available ref: KLM2096.

**VOLTAGES** 12V nominal 13.5V actual for 24V use 11.B/S. 6V applications catered for contact Kenlowe.

**TWIN FANS ALSO AVAILABLE**

As a package using one temperature control.

\* indicates standard equipment included in retrofit packages.